

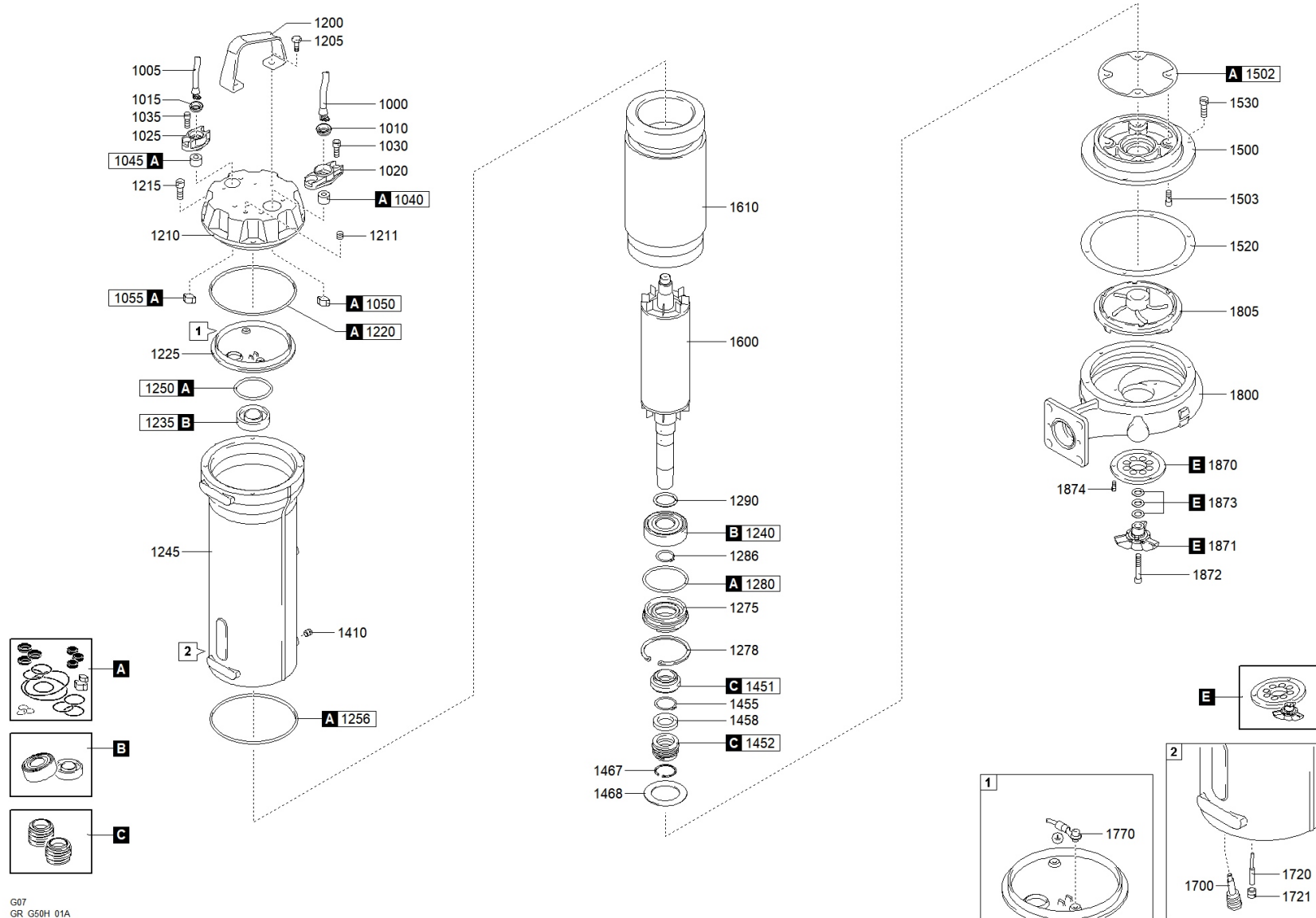

better together

1507.200 - GRG 1000/2/G50H A0FT5 NGTSB51040N00EX





better together



1507.200 - GRG 1000/2/G50H A0FT5 NGTSB51040N00EX

		Code	Description		Q.ty	Price (€)	
A		601053001	GASKETS KIT	806126	1		
C		602053093	MECHANICAL SEALS KIT	806129	1		
E		603053001	CUTTING SYSTEM KIT	806116	1		
B		604053001	BEARINGS KIT	806132	1		
1000		25020340151000001	CAVO POTENZA	802306	1		
1010		235467216820	RING NUT [POWER CABLE]	711016 OR 802074	1		
1020		235424018990	CABLE GLAND [POWER CABLE]	711014	1		
1030		270831010203200000	SCREW - CABLE GLAND [POWER CABLE]	711028	2		
1040		235673222050	RUBBER GASKET [POWER CABLE]		1		
1050		2732001400000	COLLAR CLAMP [POWER CABLE]	802081	1		
1200		235232426544	HANDLE		1		
1205		270830810201200000	SCREW [HANDLE >> COVER]	802319	2		
1210		2321171EX27210	COVER		1		
1211		270139510104000003	CAP [TIGHTNESS TEST]		1		
1215		270830810203200000	SCREW [COVER >> MOTOR CASE]	802093 OR 802095	4		
1220		271770151035000000	GASKET [COVER >> UPPER BEARING HOLDER]		1		
1225		230657125859	UPPER BEARING HOLDER		1		
1235		2729063050400000	UPPER BEARING	710969	1		
1240		2729063070200000	LOWER BEARING	802297	1		
1245		2310171EX28582	MOTOR CASE		1		
1250		271770061026000000	GASKET [UPPER BEARING]		1		
1256		271770145018000000	GASKET [MOTOR CASE >> PUMP PLATE]		1		
1275		23915087037027879	LOWER BEARING FLANGE		1		
1278		270320880200000	SEEGER [LOWER BEARING FLANGE]	802289	1		
1280		271770073035000000	GASKET [LOWER BEARING FLANGE]	711000	1		
1286		270330350100000	SEEGER [LOWER BEARING >> LOWER BEARING FLANGE]	802290	1		
1290		270220350452500000	DISTANCE RING [LOWER BEARING]	802312	1		
1410		270139510104000003	CAP [OIL CHAMBER]		1		
1451		230000010300000000	1st MECHANICAL SEAL		1		
1452		230002010300000000	2nd MECHANICAL SEAL		1		
1455		270330300100000	SEEGER [1st MECHANICAL SEAL >> 2nd MECHANICAL SEAL]	802102	1		
1467		270320620200000	SEEGER [2nd MECHANICAL SEAL]		1		
1468		270534161109027893	DISTANCE RING [2nd MECHANICAL SEAL]		1		
1500		236212003027854	PUMP PLATE		1		
1502		2750913427043	GASKET [PUMP PLATE]		1		
1503		270830810203200000	SCREW [PUMP PLATE >> MOTOR CASE]	802093 OR 802095	4		
1520		2750920022190	GASKET [PUMP PLATE >> PUMP BODY]	710949	2		
1530		270830810203200000	SCREW [PUMP PLATE >> PUMP BODY]	802093 OR 802095	4		

1600	2302351132EX27842	SHAFT WITH ROTOR		1
1610	231101323024000000	WOUND STATOR		1
1700	25072200000000	HUMIDITY PROBE [OIL CHAMBER]		1
1770	2500000001800072	GROUND CABLE CONNECTOR		1
1800	21251520020123437	PUMP BODY		1
1805	21411GR196NN27195	IMPELLER		1
1808	23913196060027230	DISTANCE RING [PUMP PLATE >> IMPELLER]		1
1809	270830810123200000	SCREW [DISTANCE RING >> PUMP PLATE]	802316	4
1809	270830810203200000	SCREW [DISTANCE RING >> PUMP PLATE]	802093 OR 802095	4
1870	211731027185	CUTTING DISK		1
1871	211631027370	CHOPPER KNIFE		1
1872	270831010703200000	LOCKING CHOPPER KNIFE		1
1873	270620180250300000	WASHER [CHOPPER KNIFE]	600678	3
1874	270830610143200000	SCREW [CUTTING DISK >> PUMP BODY]	806113	3